

A10 - Magnetic

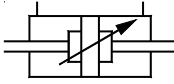

A11 - Non-magnetic

# AIR CYLINDER

## Series A10, A11

Cat No A10, A11 - 01 - 01

### AIR CYLINDERS Double Acting ( Ø32 - 100 ) mm

#### Features

- ❑ Adjustable cushioning at both ends.
- ❑ Wide varieties of mountings.
- ❑ Low friction.
- ❑ Long life.

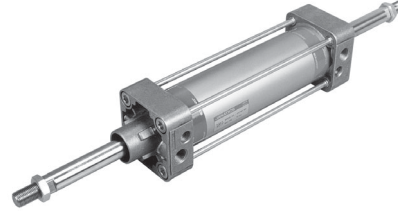

#### Technical Specifications

Cylinder bore Ø ( mm )	32	40	50	63	80	100
Cushion length ( mm )	21	23	23	23	28	28
Standard strokes* ( mm )	25 50 80 100 125 160 200 250 300 320 400 500					
Medium	Compressed air - filtered - lubricated					
Working pressure	0.5 - 10 bar					
Medium temperature	5° - 60° C					
Materials of construction	Aluminium, Brass, Nitrile, Polyurethane, Steel, Acetal					
Mountings	Basic cylinder, Foot mounting, Flange, Female clevis, Centre trunnion					
Accessories	Trunnion bracket, Rod end fork, Rod end aligner, Rod end spherical eye					

\* For Non standard or longer stroke cylinders, contact your regional dealer or **JANATICS**

#### Output force ( force in N : 1N = 0.1 kgf )

Bore Ø in mm	Rod Ø in mm	Working pressure in bar								
		2	3	4	5	6	7	8	9	10
32	12	124	187	249	311	373	435	498	559	621
40	16	190	285	380	475	570	665	760	855	950
50	20	297	445	594	742	891	1039	1187	1336	1484
63	20	505	757	1009	1261	1514	1766	2018	2270	2523
80	25	816	1225	1633	2041	2449	2857	3266	3674	4082
100	25	1325	1988	2650	3313	3976	4640	5300	5965	6625

( Above values have been worked out taking frictional loss into consideration )

#### Basic cylinder

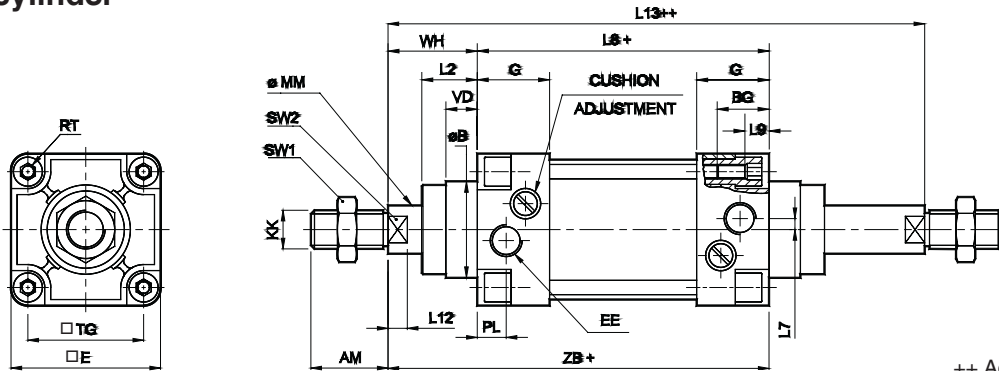

+ Add stroke  
++ Add stroke twice

Bore dia	KK	AM	MM	SW2	L12	SW1	B e11	VD	L2	E max	G	TG	RT	BG min	L9	EE	PL	L7	WH	tol	ZB	tol	L13	tol	L8	tol	Stroke tol
32	M10 x 1.25	22	12	10	6	17	30	11	20.5	44	25	32	M6	16	5	G1/8	9	0	26		120		147		94	±0.6	+2 0
40	M12 x 1.25	24	16	13	6.5	19	35	12	24.5	55	28	40	M6	16	5	G1/4	12	3	30	±1.3	135	±0.9	166	±1.5	105		
50	M16 x 1.5	32	20	16	8	24	40	13	30	63	30	48	M6	16	5	G1/4	12	5	37		143		181		106	±0.7	
63	M16 x 1.5	32	20	16	8	24	45	14.5	30.5	83	33	60	M8	16	6	G3/8	16.5	10	37		158		196		121		
80	M20 x 1.5	40	25	21	10	30	45	18	38.5	102	33	72	M10	16	6	G3/8	16	15	46	±1.7	174	±1.1	221	±2	128	±0.8	+2.5 0
100	M20 x 1.5	40	25	21	10	30	55	20	44	119	37	89	M10	16	6	G1/2	18	15	51		189		241		138		

# AIR CYLINDER

Series A10, A11

Cat No A10, A11 - 01 - 01

## MOUNTINGS FOR AIR CYLINDER Series A10, A11

### Foot mounting

+ Add stroke

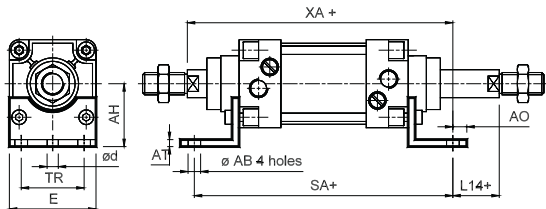

Bore dia	TR ±0.3	AB H13	AH Js15	AO max.	AT	E	d*	SA	tol	L14	tol	XA	tol	Recommended Bolt size
32	32	7	32	9	4	43	5.8	142		3		144		M6
40	36	9	36	11	4	54	7.8	161	±1.25	3	±1.5	163	±1.25	M8
50	45	9	45	11	6	62	7.8	170		6		175		M8
63	50	9	50	14	6	82	7.8	185		6		190		M8
80	63	12	63	16	6	100	9.8	210	±1.6	6	±2	215	±1.5	M10
100	75	14	71	18	6	117	11.8	220		11		230		M12

\* Suitable for reaming

### Flange

++ Add stroke twice

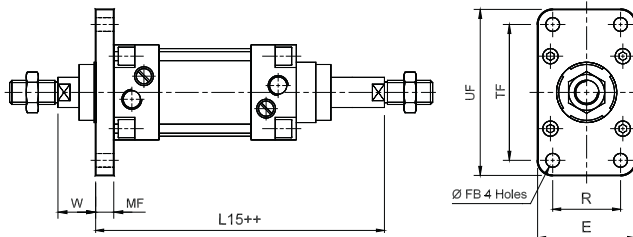

Bore dia	TF ±0.3	R ±0.3	FB H13	MF	UF	E	W	tol	L15	tol	Recommended Bolt size
32	64	32	7	10	78	46	16		131		M6
40	72	36	9	10	90	55	20	±1.5	146	±1.5	M8
50	90	45	9	12	110	65	25		156		M8
63	100	50	9	12	125	83	25		171		M8
80	126	63	12	16	155	101	30	±1.8	191	±2	M10
100	150	75	14	16	185	118	35		206		M12

### Female clevis

+ Add stroke

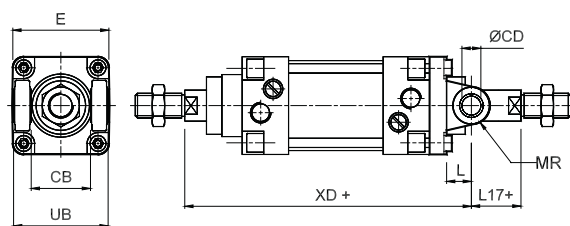

Bore dia	CD H9	CB H14	L	MR	UB h14	E max.	L17	tol	XD	tol
32	10	26	12	11	45	46	5		142	
40	12	28	15	13	52	54	6	±1.5	160	±1.25
50	12	32	15	13	60	62	11		170	
63	16	40	20	17	70	82	6		190	
80	16	50	20	17	90	100	11	±2	210	±1.5
100	20	60	25	21	110	117	11		230	

### Centre trunnion

+ Add stroke  
++ Add stroke twice

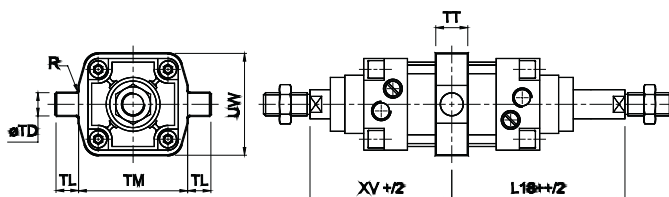

Bore dia	TD e9	TL h14	TM h14	UW	TT	R	XV	tol	L18	tol
32	12	12	50	48	16	1	73		74	
40	16	16	63	55	22	1.5	82.5		83.5	
50	16	16	75	70	24	1.6	90	±2	91	±2
63	20	20	90	86	28	1.6	97.5		98.5	
80	20	20	110	110	32	1.6	110		111	
100	25	25	132	135	40	2	120		121	

# AIR CYLINDER

Series A10, A11

Cat No A10, A11 - 01 - 01

## ACCESSORIES FOR AIR CYLINDER Series A10, A11

### Trunnion bracket

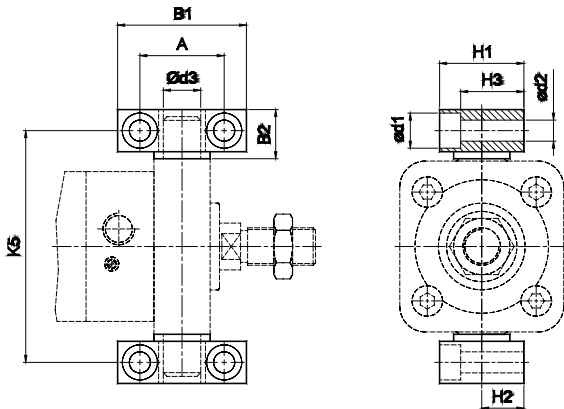

Cylinder bore Ø	B1	B2	A ± 0.2	d1	d2 H13	d3 H9	H1	H2 ± 0.1	H3	K5 Js14	Ordering no.
32	46	18	32	11	6.6	12	30	15	23	71	AT032
40	55	21	36	15	9	16	36	18	27	87	AT040
50	55	21	36	15	9	16	36	18	27	99	AT040
63	65	23	42	16.5	11	20	40	20	29	116	AT063
80	65	23	42	16.5	11	20	40	20	29	136	AT063
100	75	28.5	50	20	14	25	50	25	37	164	AT100

### Rod end Fork (ISO 8140)

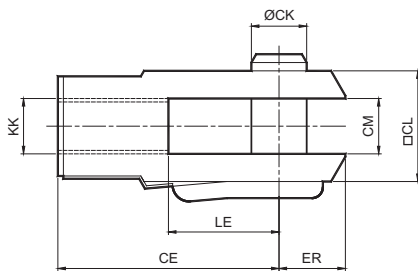

Cylinder bore Ø	KK	CE	CK f 8	CM B 12	LE	ER max.	CL	Ordering no.
32	M10 x 1.25	40	10	10	20	16	20	AF010
40	M12 x 1.25	48	12	12	24	19	24	AF012
50 / 63	M16 x 1.5	64	16	16	32	25	32	AF016
80 / 100	M20 x 1.5	80	20	20	40	32	40	AF020

### Rod end Aligner

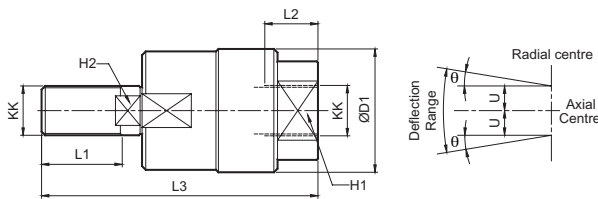

Cylinder bore Ø	KK	L1	L2	L3	H1	H2	D1	U	± θ°	Ordering no.
32	M10 x 1.25	20	14	65	17	8	28	0.75	5	AR010
40	M12 x 1.25	22	18	75	19	10	32	1	5	AR012
50 / 63	M16 x 1.5	25	22	91	27	13	41	1	5	AR016
80 / 100	M20 x 1.5	30	28	112	32	16	50	1.5	5	AR020

### Rod end spherical eye (ISO 8139)

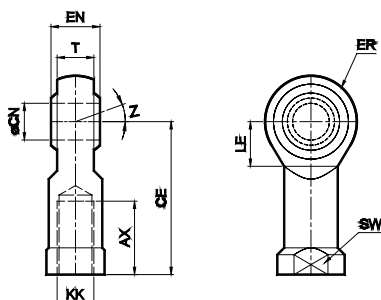

Cylinder bore Ø	KK	CN H9	T	EN h12	CE	LE min	ER max	AX	SW	Z	Ordering no.
32	M10 x 1.25	10	10.5	14	43	15	14	20	17	13°	AP010
40	M12 x 1.25	12	12	16	50	17	16	22	19		AP012
50 / 63	M16 x 1.5	16	15	21	64	22	21	28	22	15°	AP016
80 / 100	M20 x 1.5	20	18	25	77	26	25	33	30/32		AP020

# AIR CYLINDER

Series A10, A11

Cat No A10, A11 - 01 - 01

## How to order

**A**

Model		Cylinder bore (mm)		Stroke (mm)		Mountings	
10	Magnetic cylinder	032	- Ø 32	025	- 25	O	- Basic
11	Standard cylinder	040	- Ø 40	050	- 50	L	- Foot Mounting
		050	- Ø 50	080	- 80	F	- Flange
		063	- Ø 63	100	- 100	B	- Female Clevis
		080	- Ø 80	125	- 125	T	- Center Trunnion
		100	- Ø 100	160	- 160		
				200	- 200		
				250	- 250		
				300	- 300		
				320	- 320		
				400	- 400		
				500	- 500		

( For details of accessories for magnetic cylinders refer Cat No A12, A13 - 01 - 01 )

### Example:

Ordering no. for magnetic cylinder with 40 dia bore, 50 mm stroke with female clevis mounting: **A10 040 050 B**



### Note:

If ordered as 40 dia, 50 mm stroke cylinder, Basic cylinder **A11 040 050 O** will be supplied.

For repeat order when the details are taken from cylinder nameplate, mention the mounting style separately.

For ordering **Accessories** refer corresponding tables for part numbers.

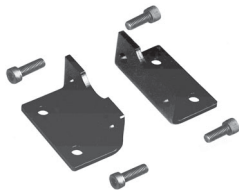
For ordering individual **Mounting** kits ( If needed separately ) the order numbers are as below

Cylinder bore Ø	Foot mounting	Flange	Female clevis
			
32	ML032	MF032	MB032
40	ML040	MF040	MB040
50	ML050	MF050	MB050
63	ML063	MF063	MB063
80	ML080	MF080	MB080
100	ML100	MF100	MB100

For your special requirements of cylinders or for further informations contact your regional dealer or **JANATICS**