

Features

- Air Screw driver
- Heavy Duty
- Double Hammer

EXPLODED VIEW

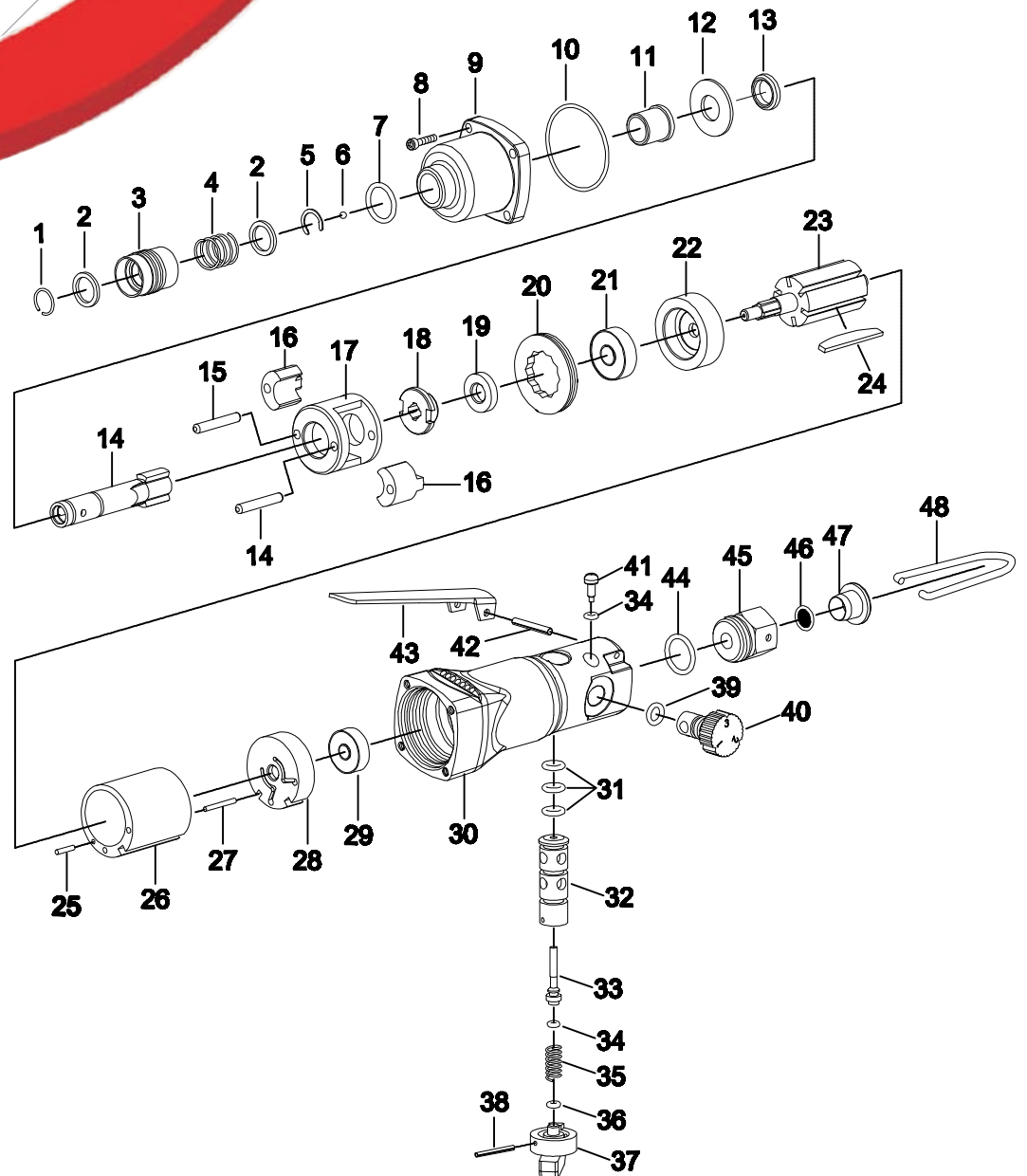

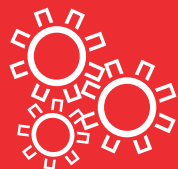

SPECIFICATION

Max. Torque: 45Nm

Bolt Capacity: 4-5 mm

Free Speed: 12000 rpm

Weight: 0.78 kg

Length: 195 mm

NO.	DESCRIPTION	Q' TY	NO.	DESCRIPTION	Q' TY
1	Check Ring	1	25	Pin(Φ2x1.8)	1
2	Lock Washer	2	26	Cylinder	1
3	Lock Sleeve	1	27	Pin(Φ2x20)	1
4	Spring	1	28	Rear End Plate	1
5	Retaining Ring	1	29	Bearing(626)	1
6	Steel Ball (Φ3.0)	1	30	Housing	1
7	O-Ring (Φ11x2)	1	31	O-Ring(Φ9.2x1.9)	3
8	Screw	4	32	Valve	1
9	Hammer Case	1	33	Valve Stem	1
10	O-Ring(Φ27x1.5)	1	34	O-Ring(Φ2.2x2)	2
11	Bushing	1	35	Spring	1
12	Washer	1	36	O-Ring(Φ4x2.3)	1
13	Adjusting Ring	1	37	Reverse Knob	1
14	Anvil	1	38	Pin(Φ2x20)	1
15	Hammer Pin	2	39	O-Ring(Φ5.6x2.2)	1
16	Hammer Dog	2	40	Regulator	1
17	Hammer Cage	1	41	Screw	1
18	Hammer Cam	1	42	Pin(Φ3x24)	1
19	Washer	1	43	Trigger	1
20	Nut	1	44	O-Ring(Φ10.5x1.8)	1
21	Bearing(608)	1	45	Inlet Adapter	1
22	Front End Plate	1	46	Air Strainer	1
23	Rotor	1	47	Plug	1
24	Rotor Blade	6	48	Hanger	1

◆The spare parts may be changed without notice.

◆Order the spare part according to the NO.